

TOP VIEW

3/4"=1'

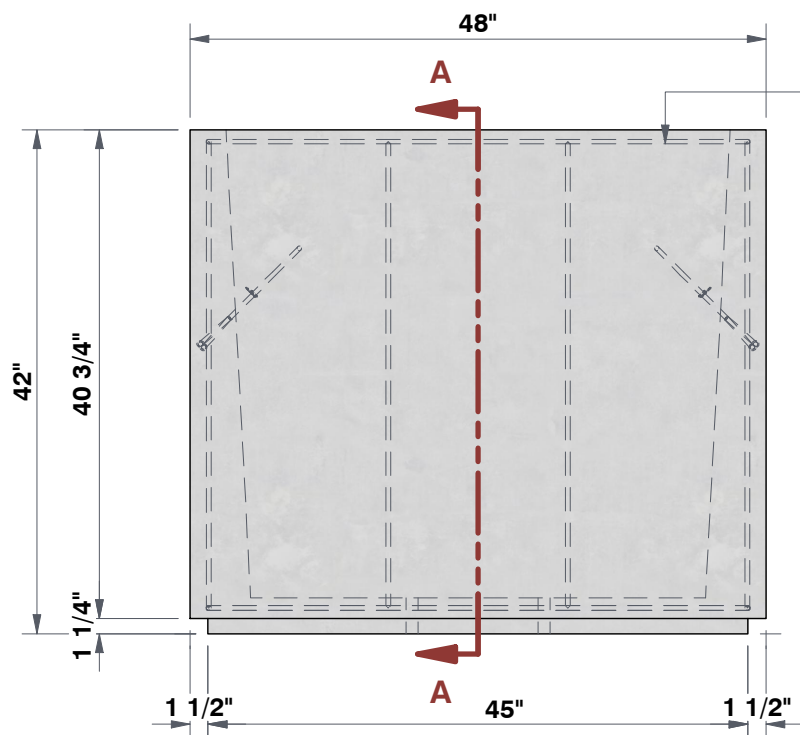

10M REBAR
WELDED CAGE

FRONT VIEW

3/4"=1'

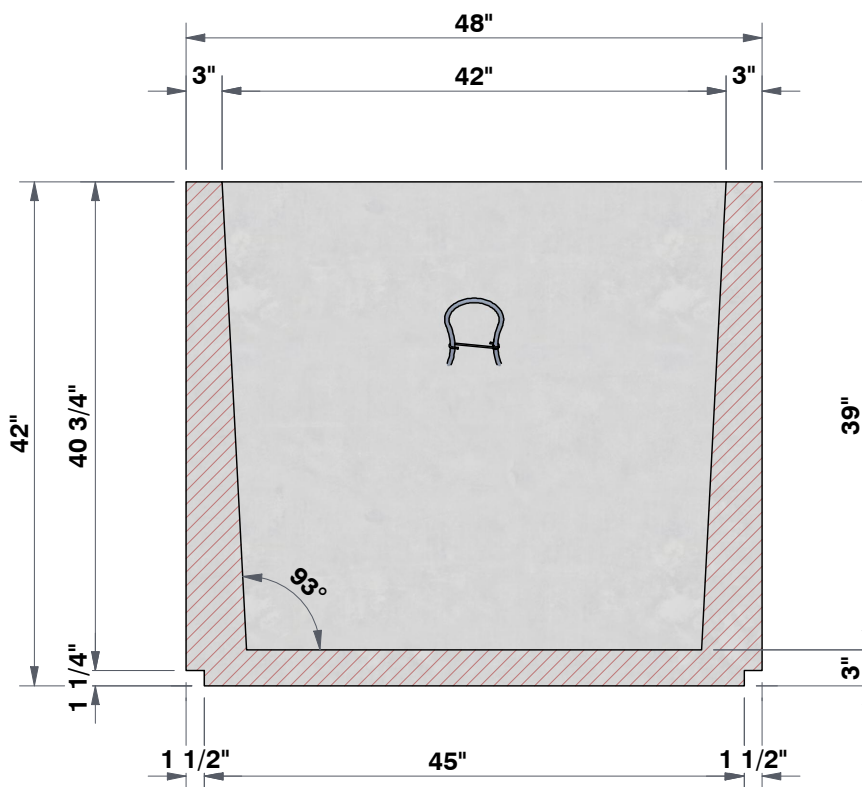

SECTION A-A

3/4"=1'

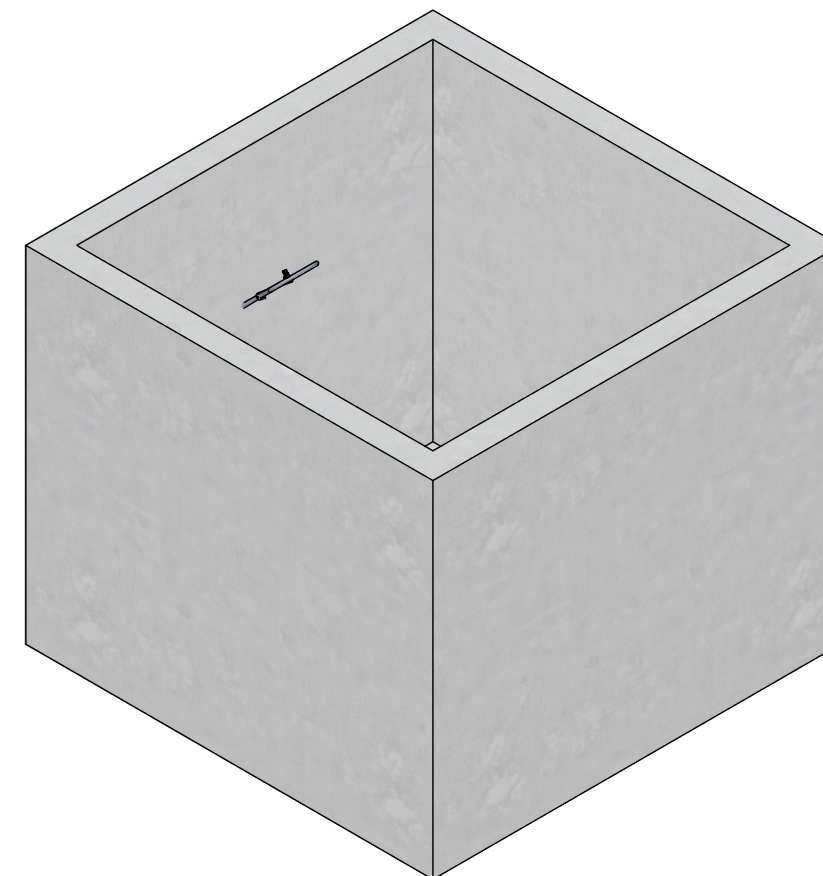

ISOMETRIC VIEW

3/4"=1'

CUSTOMER DETAIL INFORMATION

QUANTITY	
FINISH	
COLOUR	
WEIGHT	5932.68 LBS
DIMENSIONS	36" x 36" x 30"



PROJECT DESCRIPTION:

**SQUARE PLANTER
S4842**

DRAWN BY:

YJE

REQD BY:

CA

APPROVED BY:

SCALE: 3/4"=1'

DATE: 2023/8/1

SHEET NO:

1 - 1