

**TOP VIEW**  
7/8"=1'

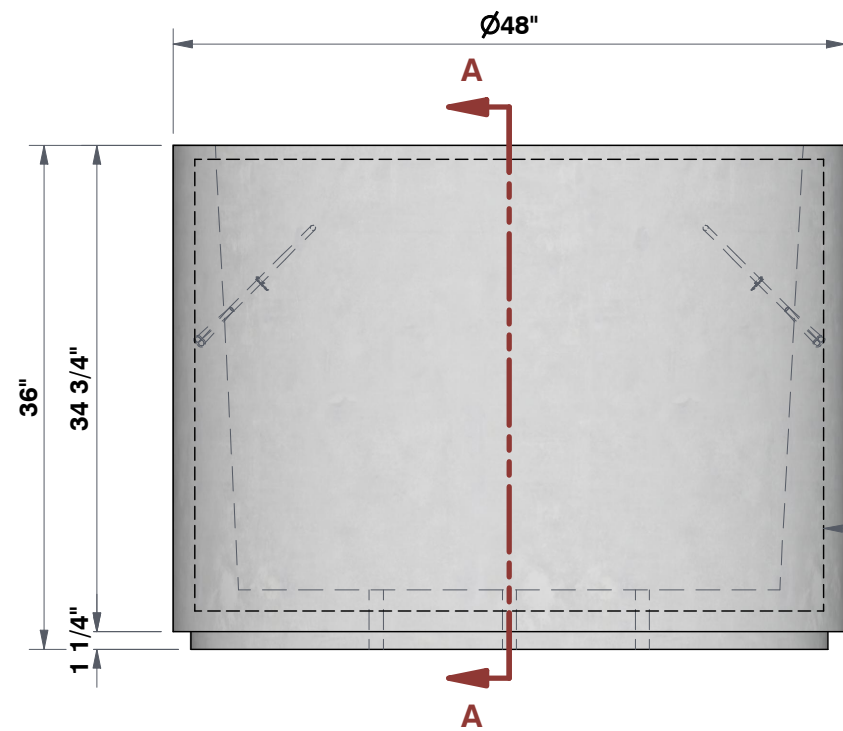

**ISOMETRIC VIEW**  
7/8"=1'



**FRONT VIEW**  
7/8"=1'

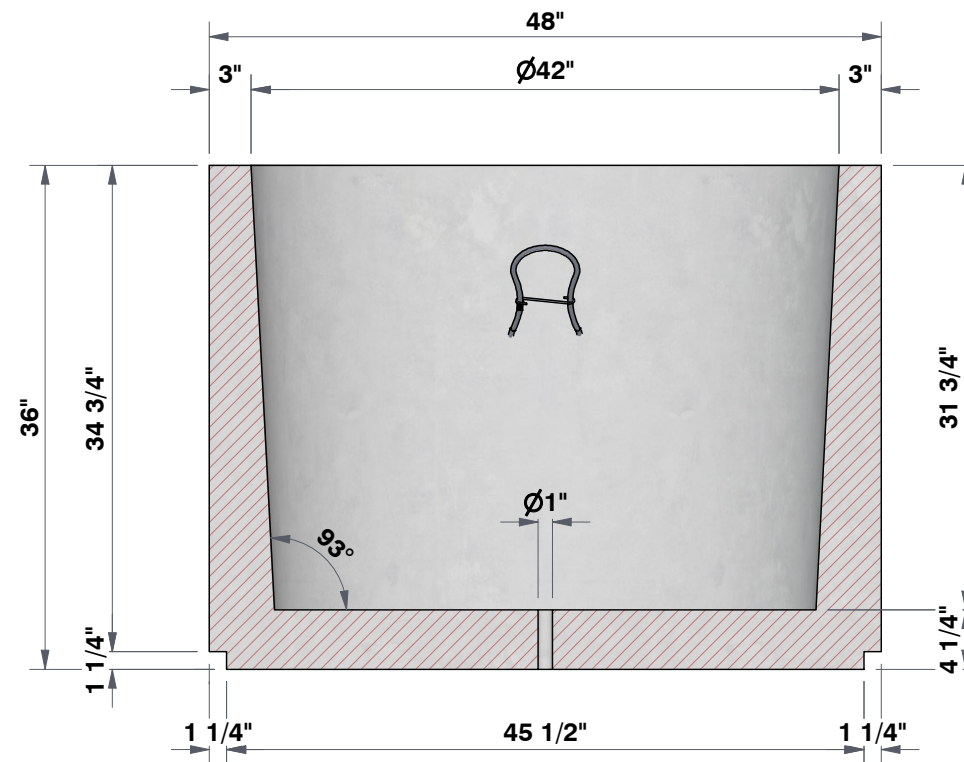

**SECTION A-A**  
7/8"=1'

4x4 W2.1/2.1  
WELDED WIRE MESH

CUSTOMER DETAIL INFORMATION

QUANTITY	
FINISH	
COLOUR	
WEIGHT	2182.65 LBS
DIMENSIONS	30"Ø x 36"



PROJECT DESCRIPTION:  
**CYLINDRICAL PLANTER  
RD4836**

DRAWN BY: **YJE**  
REQD BY: **CA**  
APPROVED BY:

SCALE: 7/8"=1'  
DATE: 2023/8/1  
SHEET NO:  
**1 - 1**