

TOP VIEW

1 1/2"=1'

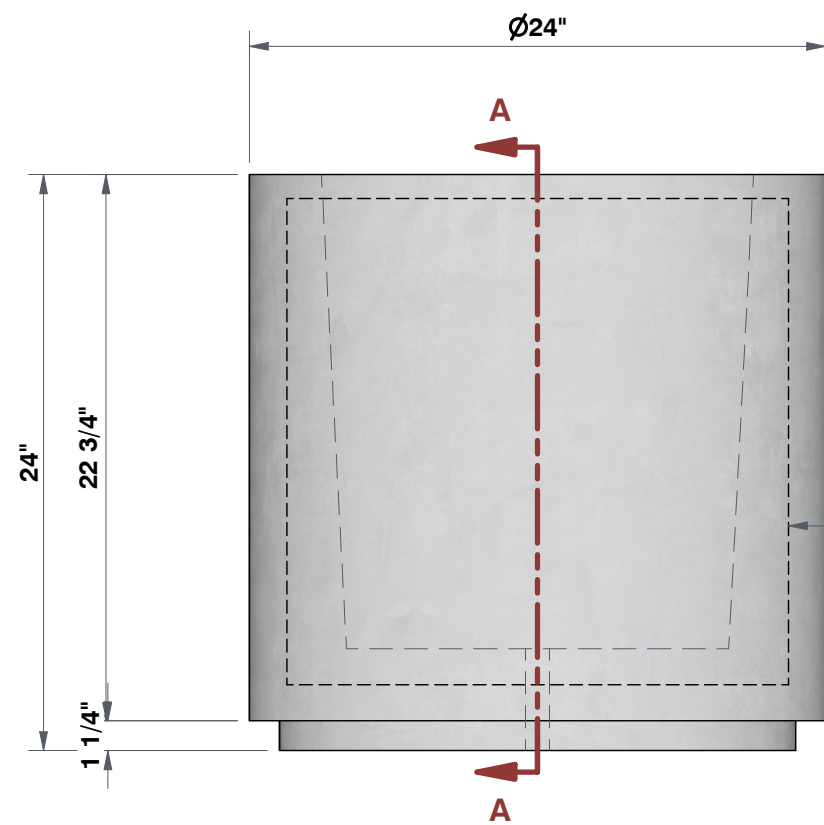

FRONT VIEW

1 1/2"=1'

4x4 W2.1/2.1
WELDED WIRE MESH

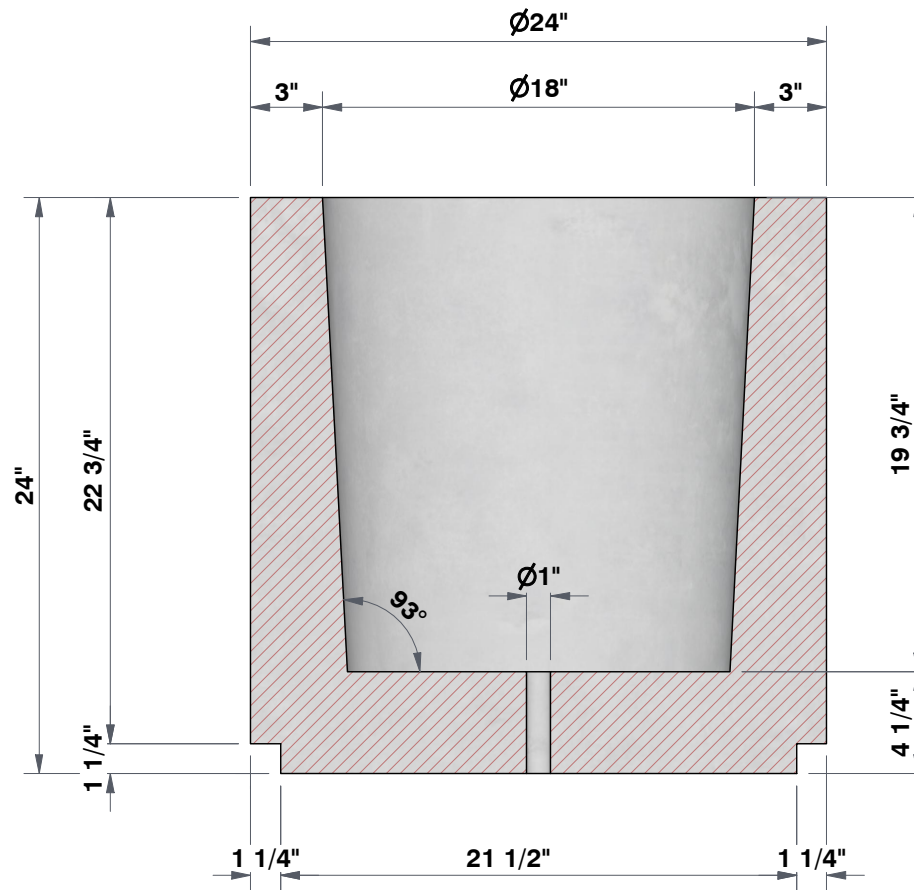

SECTION A-A

1 1/2"=1'



ISOMETRIC VIEW

1 1/2"=1'

CUSTOMER DETAIL INFORMATION

QUANTITY	
FINISH	
COLOUR	
WEIGHT	562.63 LBS
DIMENSIONS	24"Ø x 24"



PROJECT DESCRIPTION:

**CYLINDRICAL PLANTER
RD2424**

DRAWN BY:

YJE

REQD BY:

CA

APPROVED BY:

SCALE: 1 1/2"=1'

DATE: 2023/7/25

SHEET NO:

1 - 1