

TOP VIEW
5/8"=1'

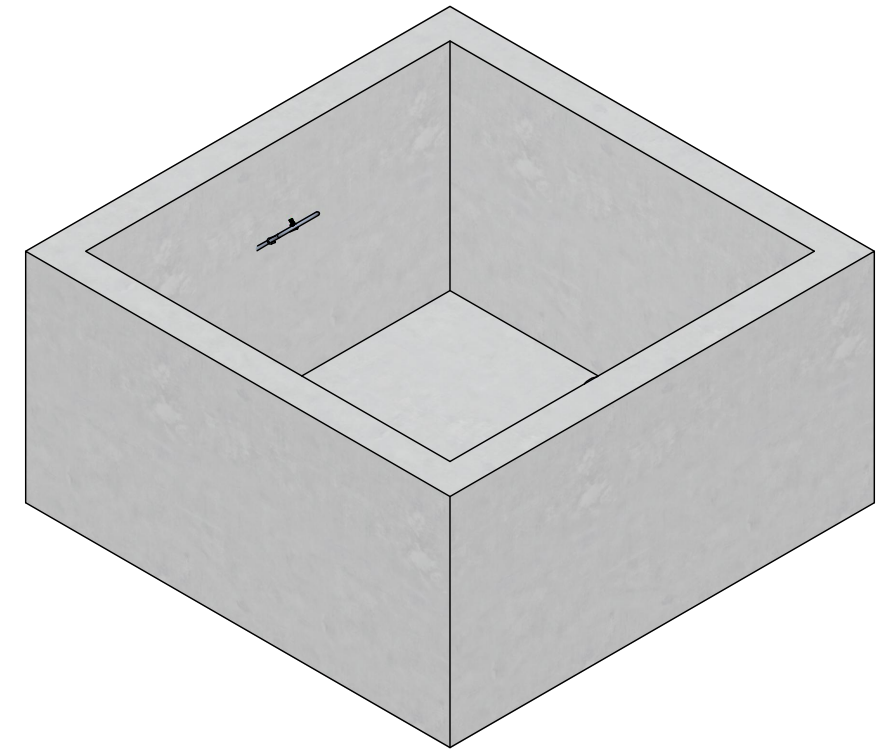

ISOMETRIC VIEW
5/8"=1'

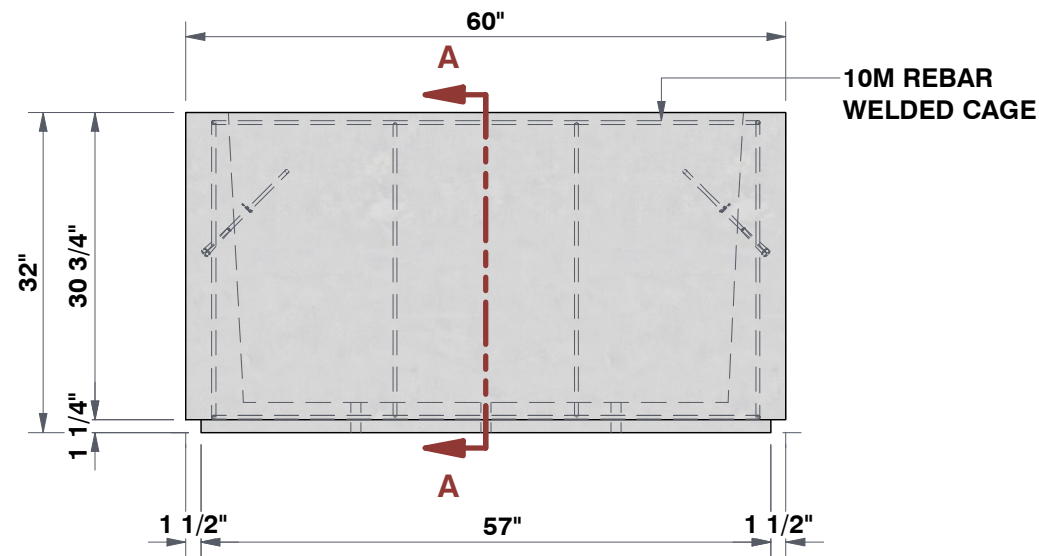

FRONT VIEW
5/8"=1'

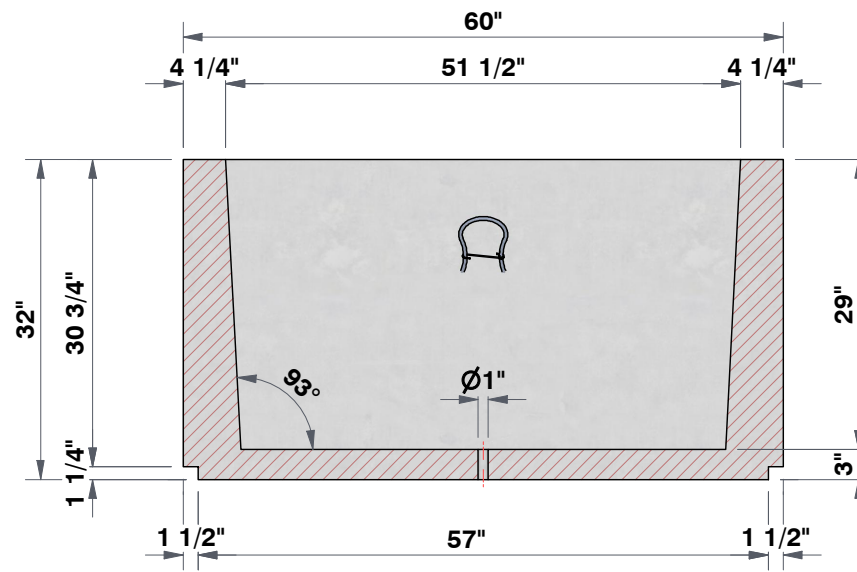

SECTION A-A
5/8"=1'

CUSTOMER DETAIL INFORMATION

QUANTITY	
FINISH	
COLOUR	
WEIGHT	6991.33 LBS
DIMENSIONS	36" x 36" x 30"



PROJECT DESCRIPTION:

**SQUARE PLANTER
S6032**

DRAWN BY: **YJE**
REQD BY: **CA**

APPROVED BY:

SCALE: 5/8"=1'

DATE: 2023/8/1

SHEET NO:

1 - 1